

Valvsys T1 DC Modulating (Servo) Use and Care Manual for FACP-181 Controller



1. INTRODUCTION

The T1 Modulating electric actuator by Valvsys, LLC brings the latest technology in valve positioning. The modulating control card allows the actuator to be positioned intermediate of full open/close. Either a 4-20mA or 1-5Vdc input signal allows complete control over the position of the valve. The actuator responds linearly to changes in input. Thus the valve is rotated in a direct proportion to a change in the input signal.

Note: this manual is for the Calibration Use and Care of the T1 Series FACP-181 DC Servo card. For the Use and Care of the valve actuator see the specific bulletin pertaining to that model such as B00019 for the NV series and B00030 for the NL series, etc. These manuals can be obtained from contacting Valvsys or visiting our web-site at www.valvsys.com.

2. FEATURES

The Valvsys T1 Modulating control card has many features that make it state of the art. Some of these features are:

- Digital setup (no trim pots to adjust)
- Microchip microprocessor with flash memory (retains software nearly indefinitely)
- 10bit Analog to Digital converter chip
- Concurrent processor algorithm with interrupt routine
- Dip Switch Settings
- 24Vdc power
- 4-20Ma - 1-5Vdc input
- 4-20mA output (RL: 250Ohm)

3. INPUT OPTIONS

The actuator can be controlled via a 4-20mA, 0-20mA, 2-10Vdc, 0-10Vdc signal. Simply adjust dip switches 5 and 6. Hook the signal to the terminal strip marked 4-20mA (-IN+) taking note of the positive and negative polarity.

4. DIRECT / REVERSE ACTION

MODE SWITCHES - Dip Switches 1-3 are used to set the action. The unit is set at the factory where the unit drives in a CW rotation upon receiving a low signal, i.e. 4mA = CW. The rotation is viewed from the top of the unit. The position of the DIP switches also determine what the unit does if the input signal is lost. See the Fig 1 to determine the proper positions.

5. SET-UP (CALIBRATION)

1. Verify that the actuator and valve move freely. Any travel stops on the valve should be removed or the actuator should be positioned to operate within those stops by rotating the manual override or by mounting the actuator in that arrangement.
2. Connect the input signal to terminals marked (-IN+). Note the direct/reverse acting requirement. See 4. above.
3. Connect power to the terminals marked (DC 24 Power). Power should be fused with an appropriate sized fast acting fuse. See the actuator nameplate for the max amp draw.

4. Once the power is connected, the unit will do a self-test. This will take approximately 2-3 seconds. Then the unit will rotate to the factory set position corresponding to the input signal given.
5. Normally "Demarcation" (setting of the span) is not necessary because the units are factory set for 90° operation. If a smaller span is required see setting the span in Section 6.

6. SPAN (AUTO DEMARCATON)

Typically the actuator is set for 90° of span. However, the modulating control card can be set up for spans less than 90°. (Note: if the unit is traveling opposite from direction expected see Direct/Reverse operation Section 4.)

1. Disconnect power to the unit.
2. Manually rotate the actuator to the end position (CW or CCW) that is going to be set. Manually position the unit so that it is physically where the 4 or 20mA signal is required.
3. Using a hex wrench on the cam assemblies loosen the set screw and rotate the cam so that the limit switch just trips (makes contact). A clicking sound will be heard.
4. Repeat for the opposite direction if required.
5. Tighten the cam set screws.
6. Connect power. Note: once power is connected the unit may run to the travel stop position and signal an alarm. The span is too far. Reset the cam so that the unit does not jam.
7. Once the cams are set, press and hold the AUTO SETTING button for at least 3 seconds.
8. The RUN lamp will light and the unit will automatically drive to each end of travel limit switch to "find" the limits. It will do this at least 2 times. It takes a couple of seconds before it moves.
9. After the unit stops, input various signal positions (0%, 50%, 100%) to verify the operation.
10. Finally, connect to the Feedback Output signal terminals and adjust the endpoints using the Output Adj trim pots.

7. FAIL ON LOSS OF SIGNAL

The unit can be calibrated to respond to a loss of signal in one of three ways; fail to the Lo input signal (4mA or 2Vdc) position, fail to the Hi input signal (20mA or 10Vdc) position, or stop.

1. MODE SWITCHES - The DIP switches are used to calibrate how the unit responds to a loss of signal. (Note: a loss of power causes the unit to stop immediately).
2. See Fig 1 to determine how to select loss of signal.

8. FEEDBACK SIGNAL (4-20MA OUT)

The unit has a built in 4-20mA signal out which can be used to determine the actuator position. Simply hook up to the terminal marked (-OUT+) to read the signal.

9. DEADBAND ADJUSTMENT

The deadband is factory calibrated. However, in some instances it may be necessary to adjust the deadband. Deadband refers to the tolerance surrounding the set point. A tight deadband makes the unit move in smaller steps. A large deadband requires bigger input changes before the unit will move. (Note that the unit has a built in delay. The unit waits a couple of seconds before responding to a signal change.) If the unit is

T1 MODULATING (SERVO) USE AND CARE Series FACP-181 Controller



"hunting" (i.e. continuous movement back and forth) the deadband will have to be increased.

1. MODE SWITCHES – DIP Switch 4 sets the deadband.
2. Switch 4 ON = a wide deadband.
3. Switch 4 Off = a narrow deadband (tight).
4. The units are factory set for a narrow (tight) deadband.
5. If the unit is continuously moving CW and CCW without a signal change then the deadband will have to be more wide (loose.)

10. WARNING

The Series FACP controller can indicate if something is wrong. A warning signal is indicated by the Yellow Lamp flashing.

1. When flashing the unit will stop responding and the problem will have to be fixed.
2. Check to see that the unit hasn't reached the end of travel limit switches. Under normal operation the unit stops before it reaches the limit switches. If for some reason it reaches the limit before the signal required position the alarm stops the unit.
3. Check to see that the motor has not overheated. It is thermally protected.
4. Check to see that the wire connections are tight.

11. TROUBLE SHOOTING

- 1 PROBLEM: There is power to the unit but it does not respond.
- 2 Verify that the correct voltage has been applied according to the ratings listed on the nameplate.
- 3 Check the wiring to verify it against the wiring schematic.
- 4 PROBLEM: Power is getting to the motor but it merely hums.
 - 4.1 Check to make sure that the proper voltage is applied and that all of the wiring connections are tight.
 - 4.2 Check to see that the unit is properly grounded.
 - 4.3 Check to see if the valve has travel stops. Remove or set the unit to run within those stops.
 - 4.4 Check the travel stops of the actuator. Verify manually that the unit operates in the correct 90° quadrant. Adjust the screw and nut on the travel stops.
- 5 PROBLEM: The actuator performs erratically.
 - 5.1 Check to see that the actuator is not stalling. Remove the actuator from the valve and verify the freeness of the valve operation.
 - 5.2 Check to see that the valve torque requirements are less than the rated torque output of the actuator.
 - 5.3 If the deadband is too tight, the unit will constantly oscillate (short strokes CW and CCW) which will heat up the motor. Increase the deadband (see deadband settings above).
- 6 Unit drives opposite of required signal position.
 - 6.1 Check the reverse/direct acting settings. See explanation above.

12. TECHNICAL ASSISTANCE

Valvsys will be more than happy to provide technical assistance should it become necessary.

Please have the following available when calling for assistance:

1. Actuator model number
2. Actuator serial number
3. Input signal being used
4. Valve application

Switch	1	2	3	4
	Action Mode	Loss of Signal		Deadband
On	Direct	Open	Close	Wide
Off	Reverse	Stop		Narrow

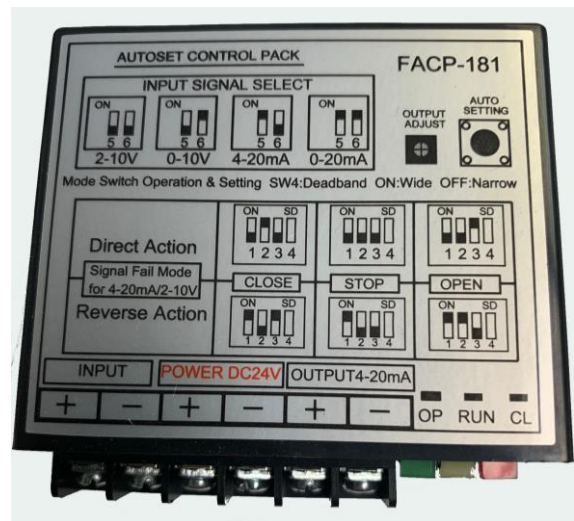
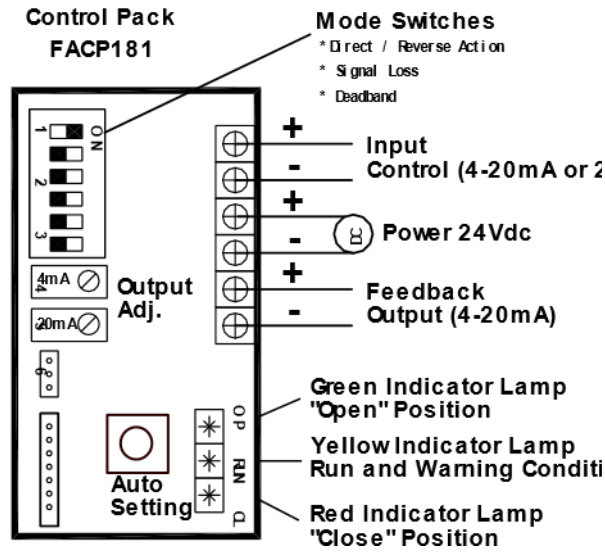

Fig. 1 – Switch Mode Settings



Control Pack Wiring

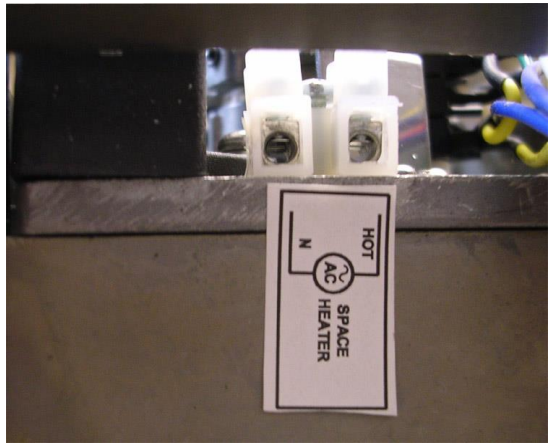

Fig. 2 – Connections

Optional 'H1' aux. heater wiring